

Client Name:		Contact Phone:
Date:	This item ID:	References PO No:
Authorised by:		Signature::
<b>Purchase order to show quantities and date required. PO to reference This Item ID</b>		

<p><b>Transition - Ellipse To Ellipse - Angled Top</b>                  A Transition between an elliptical base and an elliptical top.                  The top may be at an angle to the base and may be offset from the center line.</p>	
--	---

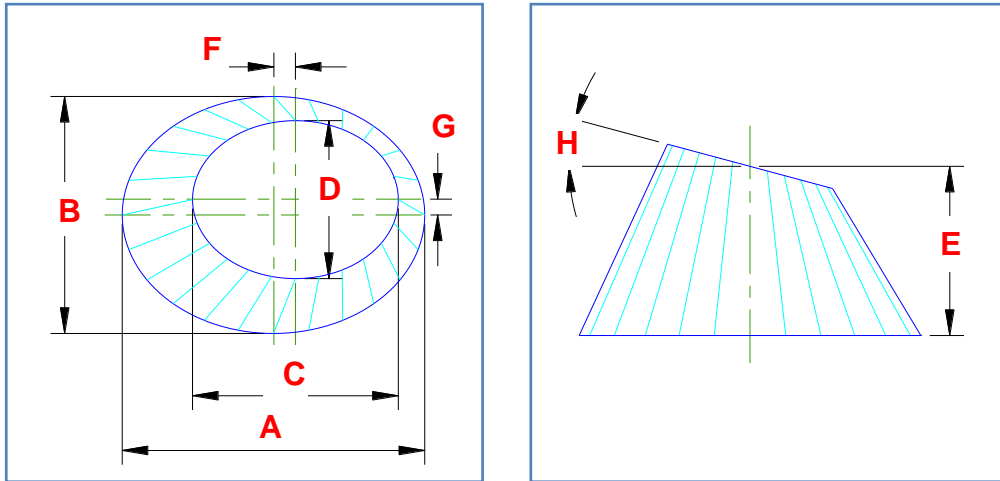

Dimension	Description	Your dimension
<b>A</b>	Base Axis X	
<b>B</b>	Base Axis Y	
<b>C</b>	Top Axis X	
<b>D</b>	Top Axis Y	
<b>E</b>	Height	
<b>F</b>	Offset X	
<b>G</b>	Offset Y	
<b>H</b>	Top Angle	

<b>Units of measure (mm, m, inch, etc):</b>				
<b>My dimensions are measured at the (tick one) :</b>		Inside <input type="radio"/>	Mean <input type="radio"/>	Outside <input type="radio"/>
<b>Material Type:</b>		<b>Material Thickness:</b>		

**ALL information in this document must be completed to produce a pattern.**  
 For further information contact details are at [www.plate-n-sheet.com.au](http://www.plate-n-sheet.com.au).

Client Name:		Contact Phone:
Date:	This item ID:	References PO No:
Authorised by:		Signature::
<b>Purchase order to show quantities and date required. PO to reference This Item ID</b>		

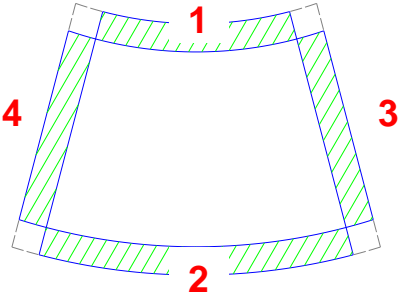
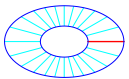
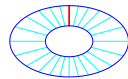
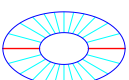
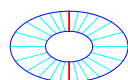
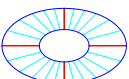
<b>Lap Details</b>				
Are overlap allowances to be added to pattern?:		YES <input type="radio"/>	NO (butt joined) <input type="radio"/>	
If YES complete table below				
	<b>Lap Number</b>	<b>Lap size</b>	<b>Notch Angle</b>	
	Lap 1			
	Lap 2:			
	Lap 3:			
	Lap 4:			
If corners are notched (as shown above) complete Notch Angle column. For example, No notch = 0 or blank, as shown = 90				
<b>Other Settings</b>				
Number of press lines			Number divisible by 4 (default = 24)	
<b>Join Options (Tick one):</b>				
	One part - Join at 0°.		One part - Join at 90°.	
	Two parts - Join at 180°.		Two parts - Join at 90.	
	Four parts - Join at 90° and 180°.			

**ALL information in this document must be completed to produce a pattern.**

For further information contact details are at [www.plate-n-sheet.com.au](http://www.plate-n-sheet.com.au).